

CAD FILE:

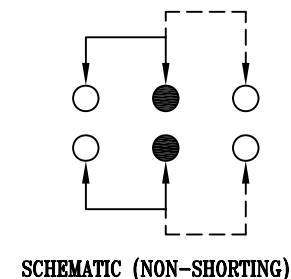

**SCHEMATIC (NON-SHORTING)**

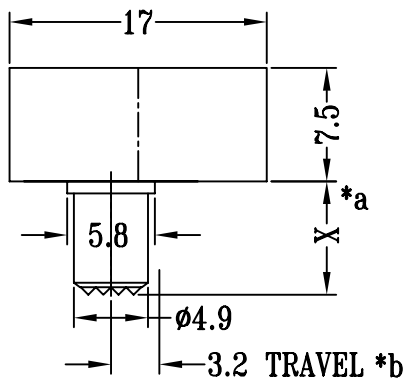
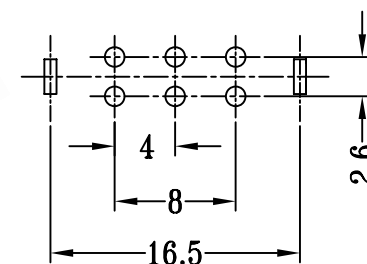
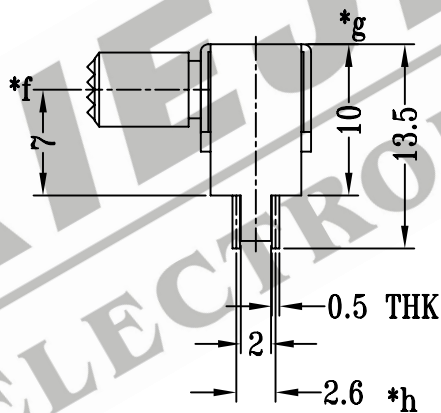
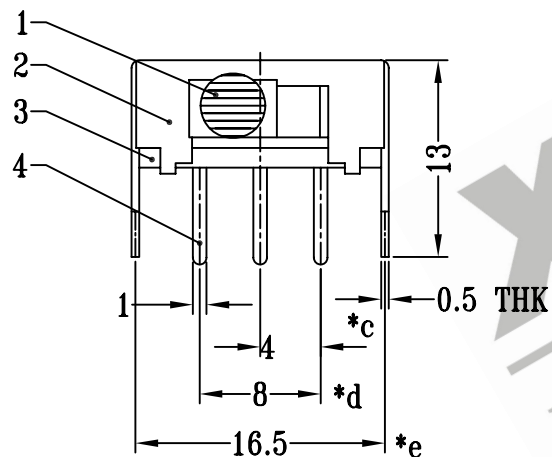

**P.C.B LAYOUT**

注:带\*表示关键尺寸(8个)

NO.	PART NAME	MATERIAL	Q'TY	FINISHING	TOLERANCE UNLESS SPECIFIED	SHENZHEN XIEJIA ELECTRONICS CO.,LTD.				
8										
7										
6	SPRING	STEEL WIRE	2	TEMPER	WITHIN: 1.5±0.1mm	ISSUE	DATE	DESCRIPTIONS		APPD.
5	CONTACT	BRASS STRIP	2	Ag PLATED	OVER : 1.5±0.2mm					
4	TERMINAL	BRASS STRIP	6	Ag PLATED OVER Ni PLATED	TITLE : HORIZONTAL SLIDE SWITCH		UNIT : MM	DRWG NO.: XJ-DR-SK22F03-00		
3	BASE	PHENOLIC RESIN	1	BLACK	MODEL: SK-22F03		SCALE: 2 : 1	DWN.	ZHOUYU	2003-11-22
2	FRAME	STEEL STRIP	1	Ni PLATED	ALL MATERIALS MUST BE COMPLIANT TO ROHS			CHK'D	FANGYING	2003-11-22
1	KNOB	POM	1	BLACK				APPD.	KANGXINAN	2003-11-22